

# Instruction of Electromagnetic Lock

## 1. Brief Introduction of Product

This lock has the most advantaged howard detecting electrocircuit, indicator of door state and detecting signal output of door state. It has a build-in demagnetizing electrocircuit to realize non-magnetic remanence at door opening; it is safer and more reliable.

## 2. Electrical features of the electromagnetic lock

The magnetic force of the lock: 280kg

Working electric voltage: 12VDC or 24 VDC]

VCC → power supply positive pole(+)

GND → power supply earth wire(-)

Working current: 500mA at 12VDC; 250mA at 24VDC

Indication of door state: green light at door open; red light at door locked

Safety mode: power on locked; power cut open

Detecting signal output of door state:

Permissible import electric voltage  $\leq 36\text{VDC/AC}$ , current:  $\leq 500\text{mA}$

NO → normally open signal

COM → neutral point

NC → normally closed signal

Adjust the wire jumper to realize the safe operation of the lock at 12VDC and 24VDC.

Connect with 12VDC, the jumper of P2 is: P2

Connect with 24VDC, the jumper of P2 is: P2

Note: the factory setting of the wire jumper is 12VDC connection.

## 3. Scheme of installation structure of the electromagnetic lock.

Exterior dimensions: 238×53×28mm    Magnetic board: 185×46×12mm

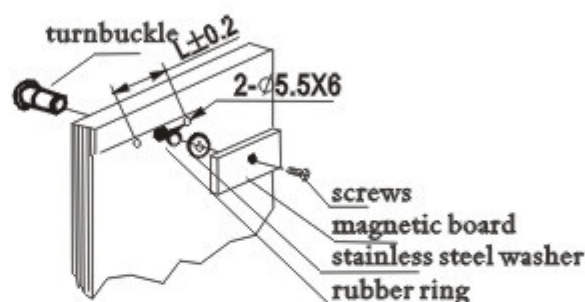
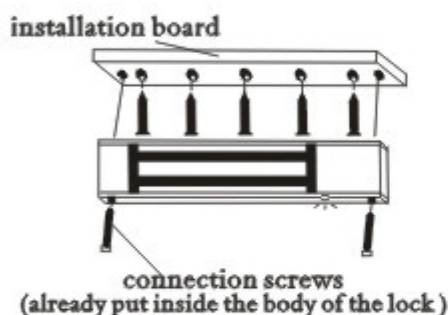

(Scheme of installation)

## Cautions:

1. The magnetic plate of the electromagnetic lock produces a strong magnetic force within an area of 20mm as the diameter. Keep the magnetic-averting objects away from the lock.
2. The binding posts are in the material package; finish the wire splice before inserting the binding posts into the lock.